

EXISTING BUILDINGS/FACILITIES			EXISTING BUILDINGS/FACILITIES		
NO	DESCRIPTION	ELEVATION FEET MSL	NO	DESCRIPTION	ELEVATION FEET MSL
105	SEWER MAINTENANCE	552.2	403	STORM WATER PUMP STATION 6	640.9
206	PRIMARY HOUSE	648.2	404	EAST SIDE RUNWAY STATUS LIGHT SHELTER	640.9
221	TRANSFORMER STATION (S)	634.0	406	MASCO HANGAR	674.5
222	TRANSFORMER STATION (B)	642.0	407	WCMA - VACANT	667.0
225	TRANSFORMER STATION (A)	640.7	408	WCMA - VACANT	672.1
282	FUEL PUMP STATION	642.9	409	OUTFALL 008A	642.0
283	AVIS (BUDGET/PAYLESS) - CAR WASH	649.3	411	STORM WATER PUMP STATION 6A	648.0
285	PUMP STATION 4	659.3	412	FIRE DEPARTMENT TRAINING CENTER	648.7
287	AVIS (BUDGET/PAYLESS) - ADMINISTRATION	666.4	414	STORM WATER PUMP STATION 6B	648.0
287A	AVIS (BUDGET/PAYLESS) - CAR WASH	649.5	415	POND 4 - OUTFALL 00A	645.3
287B	AVIS (BUDGET/PAYLESS) - PREPARATION	650.4	416	POND 3 EAST - 36.4 FLOW CONTROL STRUCTURE	643.0
288A	HERTZ RENT-A-CAR - DISPATCH	649.1	417	POND 3 EAST - OUTFALL 003A	643.7
288B	HERTZ RENT-A-CAR - SERVICE	670.3	425	SKYWEST HANGAR	706.8
288C	HERTZ RENT-A-CAR - SERVICE	663.2	427	UNITED PARCEL SERVICE HANGAR	658.8
295	AVIS RENT-A-CAR	665.0	430	CONTROL BUILDING 3L DEICING PAD	658.7
295A	AVIS RENT-A-CAR (GARAGE)	649.3	451	3W SANITARY FORCE MAIN BUILDING	642.8
330	ENTERPRISE RENT-A-CAR (ADMINISTRATION)	651.1	452	DOWNOVER TREATMENT METERING FACILITY	653.6
330A	ENTERPRISE RENT-A-CAR (SERVICE)	664.0	455	STORM WATER PUMP STATION 2	644.2
334	DOLLAR THIRTY FIREFLY (ADMINISTRATION/SERVICE)	651.6	465	DTW NODE 2	640.3
334A	DOLLAR THIRTY FIREFLY (FUEL L/D)	649.9	467	STORM WATER PUMP STATION 1	655.6
334B	DOLLAR THIRTY FIREFLY (CAR WASH)	650.1	470	SNOW REMOVAL EQUIPMENT STORAGE DEICING CONTROL BLDG.	658.7
338A	ENTERPRISE (NATIONAL/ALAMO) - DISPATCH	647.8	471	PUMP STATION 14	635.5
338B	ENTERPRISE (NATIONAL/ALAMO) - ADMINISTRATION	650.9	471A	MIDFIELD LIFT STATION	635.5
338C	ENTERPRISE (NATIONAL/ALAMO) - SERVICE	669.4	472	QSB FUEL STATION	642.0
347	REMOTE TRANSMITTER NO. 3	644.4	473	DMJR GS	641.7
348	WCMA - VACANT	666.8	474	DMJ E/G	638.7
350	MIDFIELD LIFT STATION	628.0	475	DMJ M/LSR	641.8
351	PUBLIC SAFETY/HSB	669.2	476	DMJ H/LSR	640.8
353	PUMP STATION 5	629.0	477	MALSR E/R	640.1
358A	PUBLIC SAFETY'S EQUIPMENT STORAGE	658.6	478	EPA M/LSR	649.9
359	DELTA/ENDAVOR HANGAR	700.3	479	FAA REMOTE UNIT 9B	628.5
360	SIGNATURE HANGAR	675.9	480	DELTA L/SK SKY CHEFS KITCHEN	690.3
399	DTW NODE 3	628.3	509	FIRE STATION #2	660.8
400	OLYMPIA AVIATION HANGAR	693.1	510	WEST SERVICE DRIVE LIFT STATION	632.0
			514	DELTA J SWISSPORT	699.8
			515	FORMER TERMINAL (TO BE DEMOLISHED)	710.3
			516	DELTA AIRLINES DC-10 HANGAR	727.2
			518	DELTA 747 HANGAR	741.9
			525	AT&T	654.4
			527	PUMP STATION 15	630.0
			527	WASTE DISPOSAL BUILDING	652.0
			528	DC-10 PUMP HOUSE & WATER TANKS	690.8
			529	NORTH TERMINAL FUEL FACILITY	637.8
			530	SIGNATURE HANGAR	697.5
			531	SATELLITE FUELING BUILDING	653.4
			532	CONTROL BUILDING 21R DEICING PAD	672.1
			536	DELTA CARGO	706.7
			537	DTW NODE 1	633.3
			538A	INTEGRATED DEICING SERVICES	656.1
			539	TAXISIDAN STAGING FACILITY	647.8
			540	DTW LOC	656.8
			541	DWC HALSR	642.5
			542	DTW E/G	644.5
			543	DTW LOC	650.7
			544	ASDR H/LSR	634.0
			600	DEICING CONTROL BUILDING	662.2
			601	NORTH TERMINAL	697.7
			602	WCMA ADMINISTRATION BUILDING	700.0
			604	ROGELL LIFT STATION	643.1
			605	CENTRALIZED DEICING FACILITY RAMP TOWER	675.7
			607	PARKING LOT OFFICE	650.7
			608	PARKING DECK	738.9
			610	WCMA PUBLIC SAFETY ADMINISTRATION BUILDING	665.8
			611	POWER HOUSE	651.1
			612	FAA REMOTE UNIT X1B	699.0
			612A	BACK UP GENERATOR FACILITY	641.4
			613	COMMUNICATION TOWER	646.2
			614	WCMA VACANT HANGAR	646.2
			614	WCMA - SOUTHWESTAIR GENERAL	661.4
			700	WCMA MAINTENANCE FACILITY	780.0
			701	TRAINING OFFICE	654.3
			702	AIRPORT MAINTENANCE	654.3
			703	VEHICLE EQUIPMENT REPAIR	691.2
			704	SNOW REMOVAL EQUIPMENT STORAGE	687.6
			710	REMOTE TRANSMITTER NO. 2	654.1
			711	WCMA MAINTENANCE	703.8
			712	MALSR BUILDING	653.9
			714	FEDERAL EXPRESS MAINTENANCE	661.5
			714A	SPIRIT MAINTENANCE GLOBAL AVIATION SERVICES/ CAS	665.0
			716	WCMA VACANT HANGAR	662.3
			718	'GS' BUILDING	651.3
			719	SPIRIT AIRLINES HANGAR	719.0
			720	FUEL FARM ELECTRICAL EQUIPMENT DELTA	657.8
			720B	FUEL TANK #1	675.6
			720C	FUEL TANK #4	676.7
			720D	FUEL TANK #3	676.6
			720E	FUEL TANK #5	676.4
			720F	FUEL TANK #6	676.2
			720G	FUEL FARM OFFICE	651.9
			721	STORM WATER PUMP STATION 3	653.6
			722	FUEL FARM CONTROL BUILDING	656.9
			723	FEDERAL EXPRESS CARGO	673.6
			724	'GS' BUILDING	659.0
			725	ALSF-II	668.0
			726	ALSF-III	669.2
			727	ALSF-I BUILDING	652.1
			728	ENGINE GENERATOR BUILDING	652.0
			729	DTW M/I	653.8
			730	EPA LOC	661.5
			731	SRMAM	643.4
			732	E/R LOC	648.2
			733	SR ALSF-II	644.6
			734	HUO GS	644.4
			735	EPA GS	643.2
			736	DTW GS	647.2
			737	3RD ARFF STATION	671.8
			738	PISTOL RANGE BUILDING	666.6
			738A	LIVE FIRE HOUSE	669.1
			738B	RAPELLING TOWER	685.6
			738C	STORAGE FACILITY	655.6
			738D	PUBLIC SAFETY TRAINING AIRCRAFT	640.5
			739	AIRPORT LIGHTING VAULT	662.9
			801	AIR TRAFFIC CONTROL TOWER (ATCT)	860.1
			801A	ATCT POWER AND MAINTENANCE	664.0
			802	ARFF STATION #10	674.7
			802A	ARFF STATION #10D FUEL FACILITY	642.8
			803	REGULAR BUILDING/ALV-2	659.6
			805	PUMP STATION 13	656.7
			806	NORTH TUNNEL (SAR) ELECTRICAL BUILDING	627.7
			807	DELTA EQUIPMENT REPAIR, PROSPECT AIRPORT SERVICES	676.6
			821	CENTRAL POWER PLANT	681.3
			822	TRITURATOR FACILITY	657.4
			823	GSE FUELING STATIONS	649.0
			825	PARKING GARAGE	714.8
			826	MCNAMARA TERMINAL	760.9
			830A	WEST CONCOURSE	704.0
			831	MIDFIELD TERMINAL (WESTIN)	761.5
			833	WEST SIDE RUNWAY STATUS LIGHT SHELTER	643.3
			834	GROUND FUEL OFF ENCLOSURE	661.5
			925	AIR SURVEILLANCE RADAR NO. 3 (ASR-9)	660.1
			926	FAA STORAGE	669.9
			927	DM LOC	653.3
			928	DNV VOR	628.4
			929	AT&T TELEPHONE EQUIPMENT BUILDING	659.9
			930	PUMP STATION 12	653.4
			931	FAA RTR SUPPORT BUILDING	650.3
			932	PUMP STATION 11	673.3
			934	VACANT FIELD OFFICE TRAILER	640.1
			940	PUMP STATION 9	635.0
			941	M.E.P. MAIN BUILDING	650.3
			942	M.E.P. SHELTER #2	648.7
			943	M.E.P. SHELTER #3	647.7
			944	M.E.P. SHELTER #4	645.8
			945	SOUTH EMPLOYEE LOT LIFT STATION	632.0
			950	REMOTE RECEIVER FACILITY	648.0

EXISTING OBJECT FREE AREA AND OBSTACLE FREE ZONE DIMENSIONS

RUNWAY	ROFA WIDTH (Q)	ROFA LENGTH BEYOND DER	STANDARD ROFA LENGTH	OFZ WIDTH (X)	OFZ LENGTH BEYOND DER	POFZ WIDTH	POFZ LENGTH BEYOND DER
Runway 3L	800'	1,000'	1,000'	400'	200'	None	None
Runway 21R	800'	1,000'	1,000'	400'	200'	None	None
Runway 3R	800'	1,000'	1,000'	400'	200'	None	None
Runway 21L	800'	1,000'	1,000'	400'	200'	None	None
Runway 4L	800'	1,000'	1,000'	400'	200'	None	None
Runway 22R	800'	1,000'	1,000'	400'	200'	None	None
Runway 4R	800'	1,000'	1,000'	400'	200'	None	None
Runway 22L	800'	1,000'	1,000'	400'	200'	None	None
Runway 9L	800'	350'	1,000'	400'	200'	None	None
Runway 27R	800'	1,000'	1,000'	400'	200'	None	None
Runway 9R	800'	1,000'	1,000'	400'	200'	None	None
Runway 27L	800'	920'	1,000'	400'	200'	None	None

EXISTING RUNWAY PROTECTION ZONE

RUNWAY	RPZ LENGTH (L)	RPZ INNER WIDTH (W1)	RPZ OUTER WIDTH (W2)
Arrival RPZ Runway 3L	1,700'	500'	1,010'
Arrival RPZ Runway 21R	1,700'	500'	1,010'
Arrival RPZ Runway 3R	2,500'	1,000'	1,750'
Arrival RPZ Runway 21L	2,500'	1,000'	1,750'
Arrival RPZ Runway 4L	2,500'	1,000'	1,750'
Arrival RPZ Runway 22R	2,500'	1,000'	1,750'
Arrival RPZ Runway 4R	2,500'	1,000'	1,750'
Arrival RPZ Runway 9L	1,700'	500'	1,010'
Arrival RPZ Runway 27R	2,500'	1,000'	1,750'
Arrival RPZ Runway 9R	1,700'	500'	1,010'
Arrival RPZ Runway 27L	2,500'	1,000'	1,750'
Departure RPZ Runway 3L	1,700'	500'	1,010'
Departure RPZ Runway 21R	1,700'	500'	1,010'
Departure RPZ Runway 3R	1,700'	500'	1,010'
Departure RPZ Runway 21L	1,700'	500'	1,010'
Departure RPZ Runway 4L	1,700'	500'	1,010'
Departure RPZ Runway 22R	1,700'	500'	1,010'
Departure RPZ Runway 4R	1,700'	500'	1,010'
Departure RPZ Runway 22L	1,700'	500'	1,010'
Departure RPZ Runway 9L	1,700'	500'	1,010'
Departure RPZ Runway 27R	1,700'	500'	1,010'
Departure RPZ Runway 9R	1,700'	500'	1,010'
Departure RPZ Runway 27L	1,700'	500'	1,010'

EXISTING RUNWAY SAFETY AREA

RUNWAY	RSA WIDTH (C)	RSA LENGTH BEYOND DER	STANDARD RSA LENGTH
Runway 3L	500'	1,000'	1,000'
Runway 21R	500'	1,000'	1,000'
Runway 3R	500'	1,000'	1,000'
Runway 21L	500'	1,000'	1,000'
Runway 4L	500'	1,000'	1,000'
Runway 22R	500'	1,000'	1,000'
Runway 4R	500'	1,000'	1,000'
Runway 22L	500'	1,000'	1,000'
Runway 9L	500'	911'	1,000'
Runway 27R	500'	1,000'	1,000'
Runway 9R	500'	1,000'	1,000'
Runway 27L	500'	1,000'	1,000'

*Declared Holdings applied in order to meet 1,000' RSA beyond runway end standards.

SAFETY AREA KEY MAP

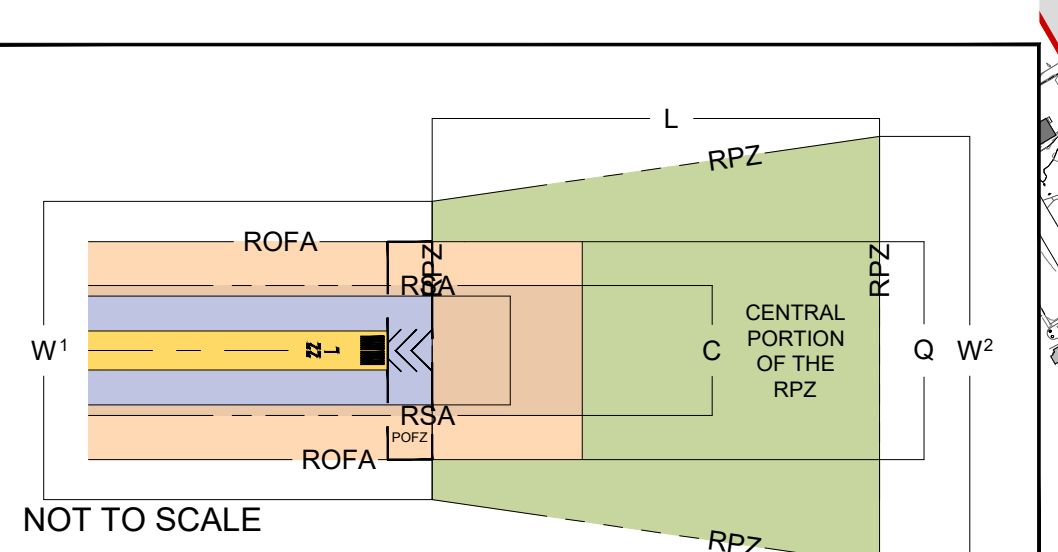

FAA DISCLAIMER
 The contents of this plan do not necessarily reflect the official views or policy of the FAA. Acceptance of these documents by the FAA does not in any way constitute a commitment on the part of the United States to participate in any development depicted therein nor does it indicate that the proposed development is environmentally acceptable in accordance with appropriate public laws.

NOTES

- ALL ELEVATIONS ARE IN FEET ABOVE MEAN SEA LEVEL (MSL).
- ALL EXISTING TAXIWAY ARE 75' IN WIDTH UNLESS OTHERWISE NOTED. EXIT TAXIWAY WIDTHS VARY DEPENDING ON LOCATION AND DESIGN.
- NON-STANDARD TAXIWAY SEPARATION OF GREATER THAN 600' IS PROVIDED IN ORDER TO MAINTAIN CLEARANCE FROM THE GLIDE.
- AIRCRAFT DESIGN GROUP VI TAXIWAY CENTERLINE TO PARALLEL TAXIWAY CENTERLINE SEPARATION WAS UTILIZED TO PRESERVE THE ABILITY FOR FUTURE LARGE AIRCRAFT TO ACCESS RUNWAY 27L FOR DEPARTURE.
- AIR TRAFFIC CONTROL TOWER CAB EYE LEVEL HEIGHT IS 801' MSL BASED ON JANUARY 2010 SURVEY.
- HORIZONTAL DATUM: NORTH AMERICAN DATUM OF 1983 (NAD 83) 2010.00 ADJUSTMENT.
- VERTICAL DATUM: NORTH AMERICAN VERTICAL DATUM 1988 (NAV D 88).
- THE BUILDING RESTRICTION LINE (BRL) IS A COMPOSITE OF THE PART 77 30' CONTUR, TOFA, RPZ, AND NAVIAD CRITICAL AREAS.

DRAWING LEGEND

APPROVAL
 WAYNE COUNTY AIRPORT AUTHORITY
 BY: CHIEF EXECUTIVE OFFICER
 DATE: _____

APPROVAL
 HNTB
 DATE: _____

NO.	DATE	REVISION
1	11/21	Runway 3L, 21R and CDF Update
2		
3		
4		
5		
6		

DETROIT METRO • WILLOW RUN
 WAYNE COUNTY AIRPORT AUTHORITY

HNTB